



"PVL" SERIES

Fixed Displacement - Single

PVL1

VANE PUMPS

Up to 5 MPa (730 PSI), 10.6 cm³/rev (.647 CU.IN./rev)

The PVL series single pumps are designed for use with small size machine tools requiring comparatively low pressure and small flow rates.

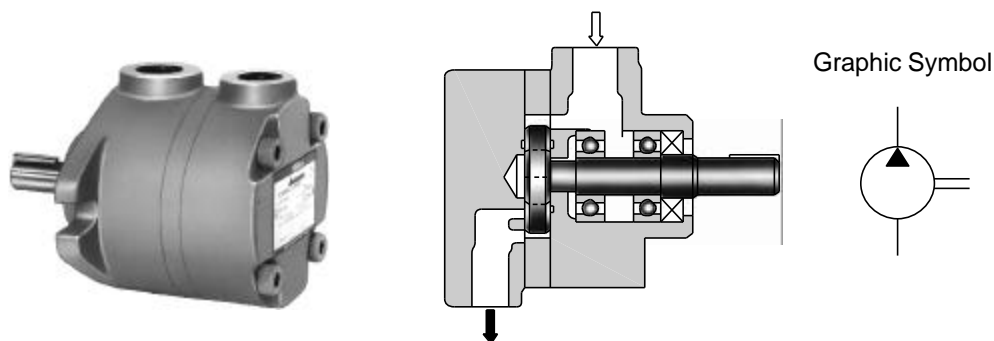

Specifications

Model Numbers	Geometric Displacement cm ³ /rev (cu.in./rev)	Max. Operating Pressure MPa (PSI)	Output Flow & Input Power	Shaft Speed Range r/min		Approx. Mass kg (lbs.)	
				Max.	Min.	Flange Mtg.	Foot Mtg.
PVL1- 2-* -RA-* -31/3180/3190	1.5(.092)	5 (730)	Refer to Page 5	1800	950*	3.3 (7.3)	5.7 (12.6)
PVL1- 3-* -RA-* -31/3180/3190	2.7(.165)						
PVL1- 4-* -RA-* -31/3180/3190	3.7(.226)						
PVL1- 6-* -RA-* -31/3180/3190	5.7(.348)						
PVL1- 8-* -RA-* -31/3180/3190	7.8(.476)						
PVL1-11-* -RA-* -31/3180/3190	10.6 (.647)						

★ However, when starting the pump at low speed, maximum viscosity is restricted. Refer to Page 2, item "Hydraulic Fluids" for maximum viscosity.

Model Number Designation

PVL1	-4	-L	-R	A	-K	-31	*
Series Number	Nominal Displacement cm ³ /rev	Mounting	Direction of Rotation	Discharge Port Position	Shaft Extension	Design Number	Design Standard
PVL1 (Threaded) (Connections)	2 3 4 6 8 11	L: Foot Mtg. F: Flange Mtg.	(Viewed from Shaft End) R: Clockwise★1 (Normal)	A: Upwards (Normal)	K: Keyed Shaft V: Tang Shaft	31	Refer to★2

★ 1. Available to supply pump with anti-clockwise rotation. Consult Yuken for details.

★ 2. Design Standards: None..... Japanese Standard "JIS"
80..... European Design Standard
90..... N. American Design Standard



■ Hydraulic Fluids**1. Type of Hydraulic Fluids**

Petroleum Base Oils..... Use R&O (Rust and Oxidation inhibitor) type oils or anti-wear type oils.
(equivalent to ISO VG-32 or 46)

Note: Only Petroleum Base Oils can be used for hydraulic fluids.

2. Recommended Viscosity and Oil Temperature

Viscosity ranging between 20 - 400 mm²/s (100 - 1800 SSU).

Oil temperatures between 0/+70℃ (32 - 158℉)

Use hydraulic fluids which satisfy the recommended viscosity and oil temperatures given above.

Note that if the PVL1 pump is started at a low speed of 950 r/min, the maximum fluid viscosity is limited to 200 mm²/s (910 SSU).

3. Control of Contamination

Contamination of hydraulic fluids results in pump failures and reduced pump lives. Carry out sufficient contamination control for hydraulic fluids and keep contamination level within NAS class 12.

Also, use a 100 μm (150-mesh) tank filter on the suction side and install it more than 50 mm (2 in.) away from the tank bottom.

■ Instructions**1. Alignment of Shaft**

Employ a flexible coupling whenever possible, and avoid any stress from bending or thrust.

Maximum permissible misalignment is less than 0.1 mm (.004 inches) TIR and maximum permissible misangular is less than 0.2°

2. Suction Pressure

Set the suction pressure within -20 to +30 kPa (5.9 in. Hg vacuum to +4.3 PSIG) at the pump inlet.

In addition, use suction pipes having the sizes shown in the dimensional drawings. If the pump is installed above the tank level, set the suction port more than 1.0 m (3.3 ft.) below from the oil level.

3. Precautions at Starting

At an initial operation or at an operation after a long rest, the pump may have difficulty in sucking up the fluid. In such cases, an air bleed valve should be installed beforehand on the discharge side (model No. ST1004-* -10*, catalogue No. Pub. EC-3001.), or discharge air by slightly slackening the connection on the discharge side. At starting, operate the pump intermittently as far as possible with no load.

For fluid viscosity at starting, see the item "Hydraulic Fluids" above.

4. Other Precautions

If a PVL1 series single pump is used at speed below 1200 r/min, install the pump with the suction port upside so that the pump can suck up the fluid easily at starting.

Flange Mtg.

Keyed Shaft: PVL1-* -F-RA-K-31/3180/3190

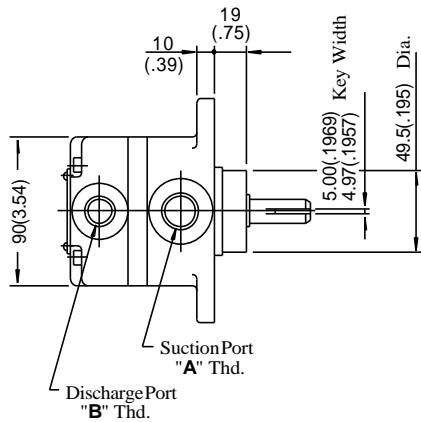

Tang Shaft.

PVL1-* -F-RA-V-31/3180/3190

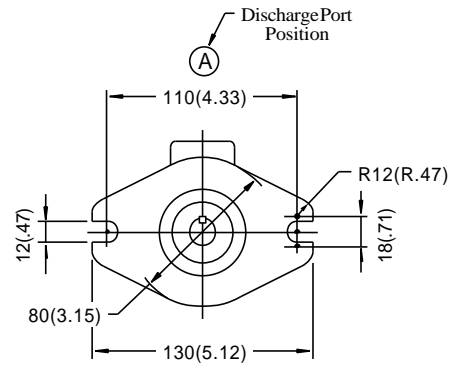
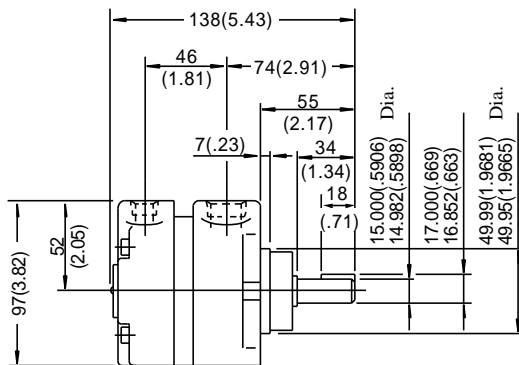
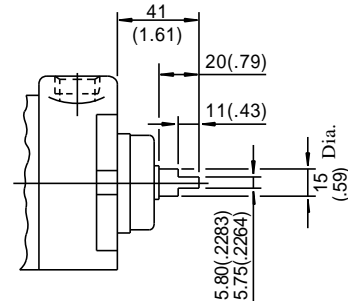

Model Numbers	"A" Thd.	"B" Thd.
PVL1-* -F-RA-K-31	Rc 1/2	Rc 3/8
PVL1-* -F-RA-K-3180	1/2 BSP.F	3/8 BSP.F
PVL1-* -F-RA-K-3190	1/2 NPT	3/8 NPT

**DIMENSIONS IN
MILLIMETRES (INCHES)**

Foot Mtg., Keyed Shaft: PVL1-* -L-RA-K-31/3180/3190

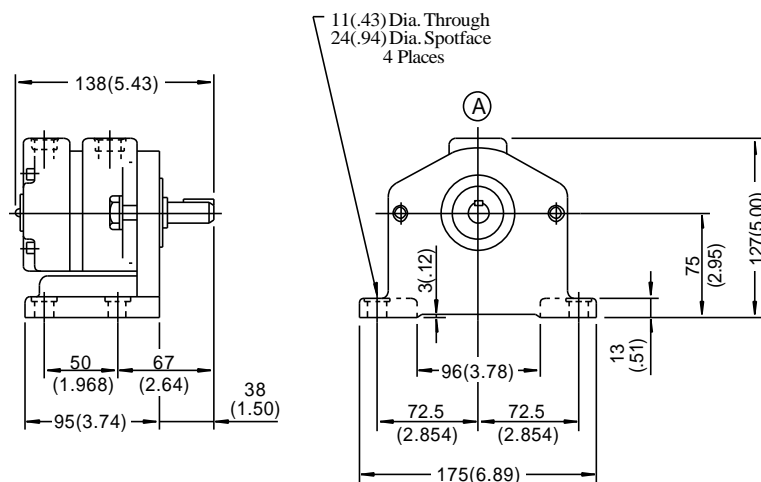

• For other dimensions, refer to "Flange Mtg.".

CAUTION

When making replacement of seals or bearing, please do it carefully after reading through the relevant instructions in the Operator's Manual.

PVL1-*-*-RA-* -31/3180/3190

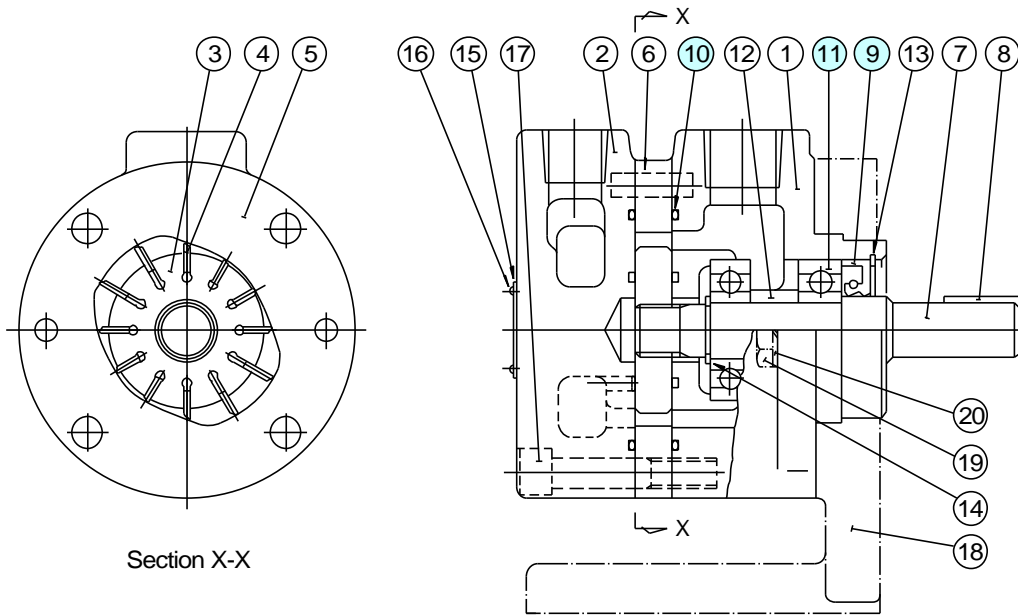

Item	Name of Parts	Part Numbers	Qty.	Remarks
9	Oil Seal	ISD 20 35 8	1	} Included in Seal Kit (Kit No. : KS-PVL1-31)
10	O-Ring	S60	2	
11	Bearing	6003	2	

Typical Noise Level Characteristics

Measuring conditions

Oil viscosity 20 mm²/s (100SSU)
 Point of measurement one metre (3.3 ft.) horizontally away from pump head cover
 Back ground noise level 40 dB (A)

PVL1-2

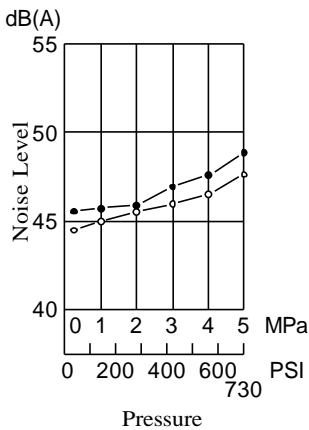

PVL1-3

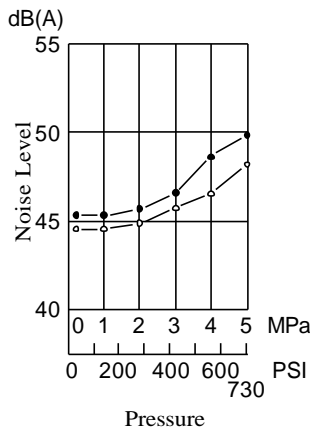

PVL1-4

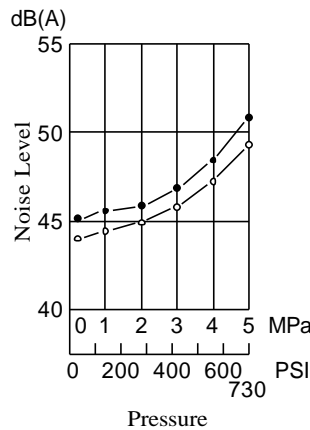

PVL1-6

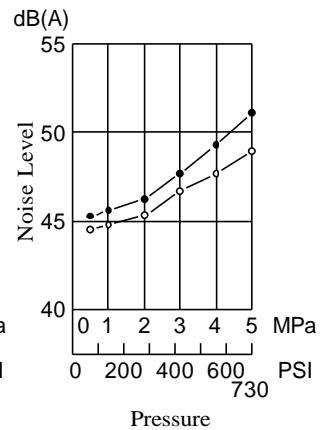

Viscosity 20 mm²/s (100 SSU) [ISO VG32 oils, 50 蛸 (122 蛸)]

● **PVL1-2**

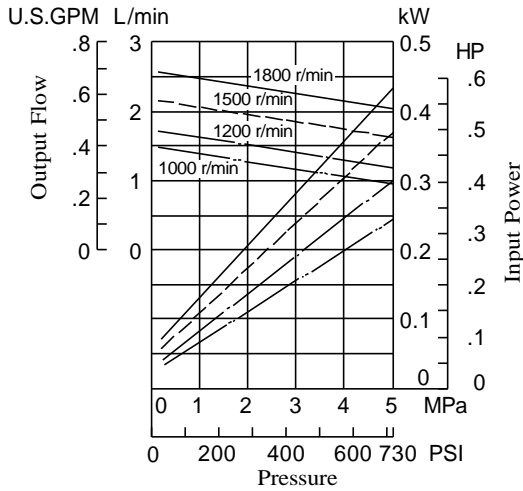

● **PVL1-3**

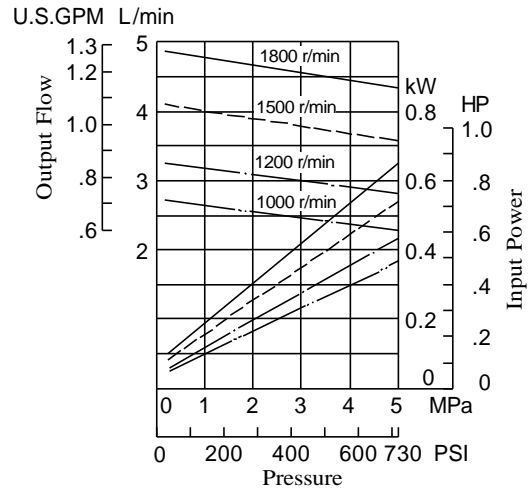

● **PVL1-4**

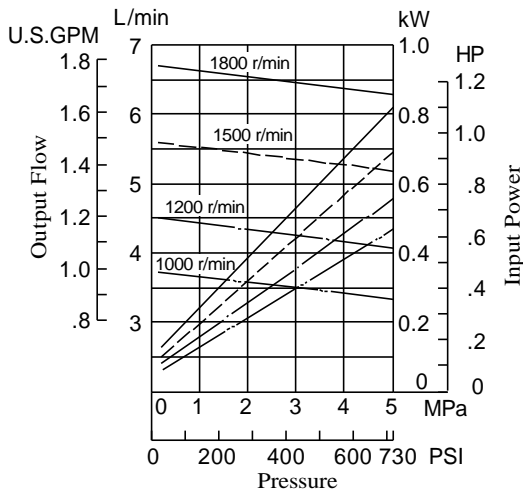

● **PVL1-6**

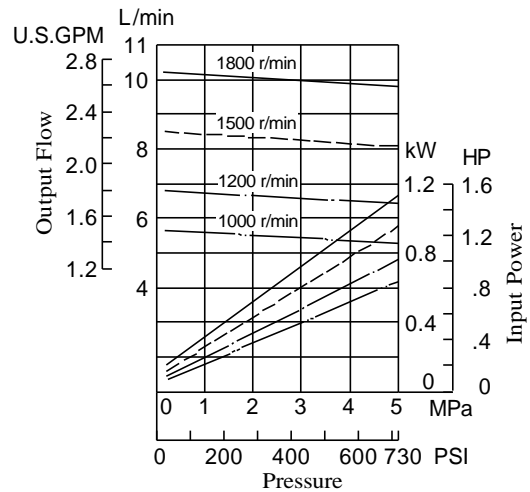

● **PVL1-8**

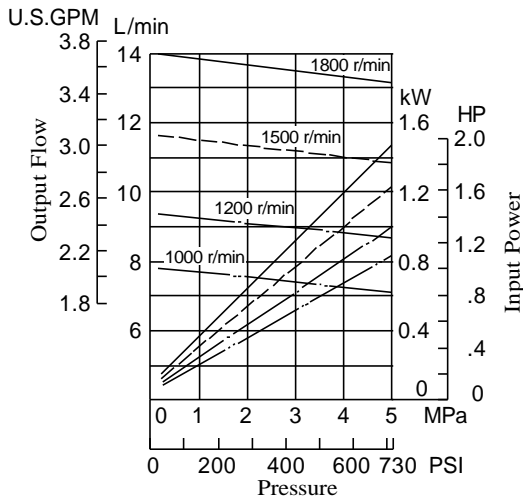

● **PVL1-11**

